

**NEW**



# STEEL PUMP JACK SYSTEM



## SYSTEM COMPONENTS

- Pump Jack
- Work Bench with Guardrail Holder
- Pole Anchor
- Foldable Brace



A10.8.2000



The #1 Brand in Professional Climbing Equipment.

# A Versatile and Durable from the Most Trusted

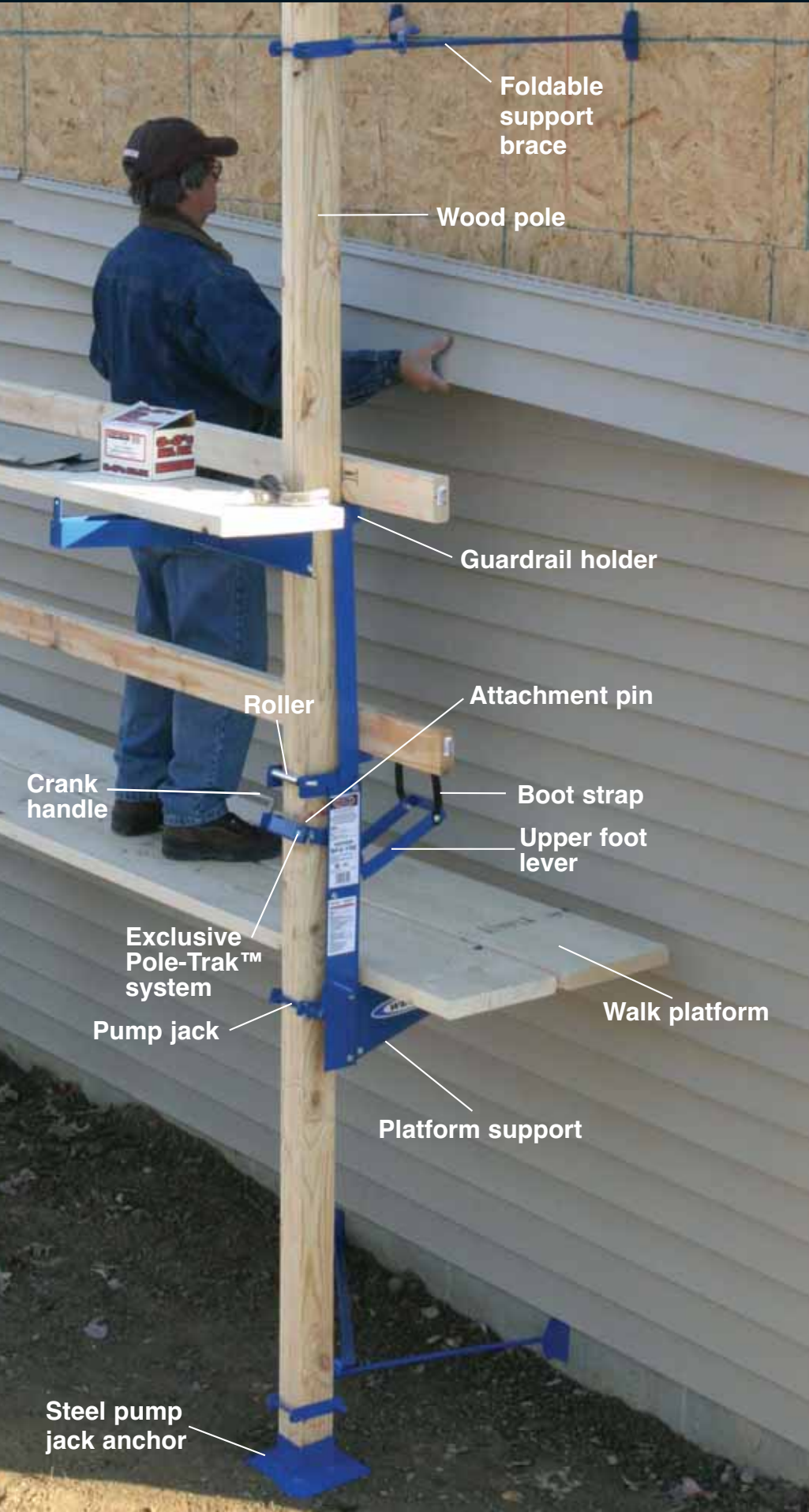

Foldable support brace

Wood pole

Guardrail holder

Roller

Attachment pin

Crank handle

Boot strap

Upper foot lever

Exclusive Pole-Trak™ system

Pump jack

Walk platform

Platform support

Steel pump jack anchor



- Exclusive Pole-Trak™ system with rugged hand crank and safety brake



- Slip-resistant foot lever with oversized boot strap



- Accommodates up to a 24" wide plank

NOTE: When working 10 ft and above, OSHA requires fall protection. Refer to product labels.

# A Versatile and Durable Steel Pump Jack System from the Most Trusted Name in Ladders



- Exclusive Pole-Trak™ system with rugged hand crank and safety brake



- Slip-resistant foot lever with oversized boot strap



- Accommodates up to a 24" wide plank

NOTE: When working 10 ft and above, OSHA requires fall protection. Refer to product labels.

## SYSTEM COMPONENTS

Foldable Support Brace  
model #SPJ-SBF



### FOLDABLE BRACE

- Easily attaches to pole.
- Swivels to allow easy attachment.
- Provides triangular bracing.

Work Bench/  
Guardrail holder  
model #SPJ-WB



### WORKBENCH/GUARDRAIL HOLDER

- Easily attaches to pole and provides a work surface.
- Provides work surface at various heights.
- Accommodates up to 20' of height.

Guardrail Holder  
model #SPJ-GRH



### GUARDRAIL HOLDER

- Easily attaches to pole.
- Provides for 2x4 upper rail (per OSHA).

Pump Jack  
model #SPJ-100



### PUMP JACK (SPJ-100)

- Powder coated steel for durability.
- Ribbed side plates for added stability.
- Large boot strap for ease of use.
- Large, slip-resistant foot lever.
- Crank handle safety latch.
- Accommodates up to 24' of height.

Pole Anchor  
model #SPJ-PA-4



### POLE ANCHOR (SPJ-PA-4)

- Easily attaches to pole.
- Provides a mudsill when not available.

# le Steel Pump Jack System Name in Ladders

**NEW**

## SYSTEM COMPONENTS

Foldable Support Brace  
model #SPJ-SBF



### FOLDABLE BRACE (SPJ-SBF)

- Easily attaches to pole.
- Swivels to allow easy attachment.
- Provides triangular bracing (per OSHA).

Work Bench/  
Guardrail holder  
model #SPJ-WB



### WORKBENCH/GUARDRAIL HOLDER (SPJ-WB)

- Easily attaches to pole and pump jack.
- Provides work surface at comfortable user height.
- Accommodates up to 20" wide platforms.

Guardrail Holder  
model #SPJ-GRH



### GUARDRAIL HOLDER (SPJ-GRH)

- Easily attaches to pole.
- Provides for 2x4 upper and mid-level guardrails (per OSHA).

Pump Jack  
model #SPJ-100



### PUMP JACK (SPJ-100)

- Powder coated steel for appearance and durability.
- Ribbed side plates for added strength and twist-resistance.
- Large boot strap for ease of use.
- Large, slip-resistant foot lever.
- Crank handle safety latch.
- Accommodates up to 24" wide platforms.

Pole Anchor  
model #SPJ-PA-4



### POLE ANCHOR (SPJ-PA-4)

- Easily attaches to pole.
- Provides a mudsill when firm base for pole is not available.



# STEEL PUMP JACK SYSTEM

- Exclusive Pole-Trak™ system with rugged hand crank and safety brake
- Slip-resistant foot lever with oversized boot strap
- Accommodates up to a 24" wide plank
- Economical and easy to operate
- OSHA and ANSI approved

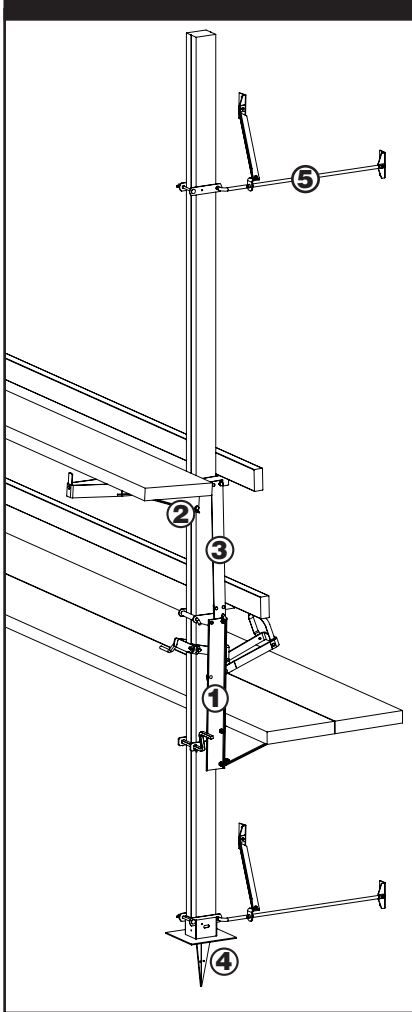

## 250<sup>RATED LOAD</sup> lbs.

*Combined Weight of User and Materials  
Maximum load not to exceed rated load  
of either plank or pump jack.*

### Components shown

Description	Model Number	Carton Height (in)	Carton Width (in)	Carton Length (in)	Product Weight (lbs)	Qty Per Carton
① Steel Pump Jack	SPJ-100	26.1	6.3	19.3	23.0	1.00
② Steel Work Bench/ Guardrail Combo	SPJ-WB	26.1	6.0	10.1	11.0	1.00
③ Steel Guardrail Holder	SPJ-GRH	26.2	5.8	6.8	5.5	1.00
④ Steel Pump Jack Pole Anchor (4 Pk)	SPJ-PA-4	8.8	24.5	17	23.0	4.00
⑤ Steel Pump Jack Foldable Support Brace	SPJ-SBF	1.8	6.9	48.7	7.0	1.00

NOTE: When working 10 ft and above, OSHA requires fall protection. Refer to product

## Easy Set Up\*

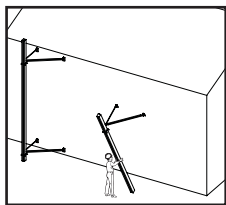

**1** Install wood pole to work wall

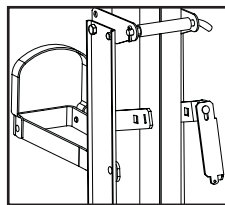

**2** Install Steel Pump Jack to Wood pole

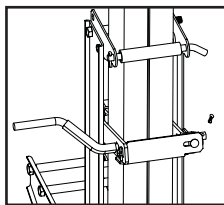

**3** Close pole latch insert crank handle

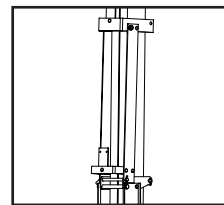

**4** Install work bench to Pump Jack

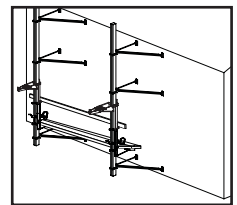

**5** Install walk platform

\*Note: Be sure to follow all safety and assembly instructions.



A 10.8.2000